

# VITEA<sup>®</sup> CARE

## Instructions for use

Edition EJ 02.2026



CE

## REAR ASSIST DRIVE - WAY

### Catalogue number: DRVK0M\_PP

 **MDH**<sup>®</sup>  
Sprzet Medyczny





# Instructions for use

## TABLE OF CONTENT

1. Introduction	3
1.1 Product description	3
2. Usage	5
2.1 Assembly - cross frame wheelchair	5
2.2 Assembly - fixed frame wheelchair	6
2.3 Further assembly stages	6
3. Everyday use and maintenance	9
4. Drive module parameters and standards	10
5. Contact details	11

Always follow precautions according to the safety information provided below when using the product. Read the entire manual carefully before use. Keep this manual for future reference.



# 1. INTRODUCTION

Thank you for choosing our product. We are deeply convinced that it will meet your expectations. Please read this document before using it for the first time. This manual is implemented to provide you with the necessary information on the safe use of the device. Correct compliance with the recommendations will significantly contribute to extending the durability and aesthetics of the product. We would like to point out that we are constantly trying to improve the quality of our products, which may result in minor changes that are not included in the manual.

**Indications:** A powered wheelchair electric is a quality of life device designed to ensure mobility.

**Contraindications:** Contraindications for sitting position.

## 1.1. PRODUCT DESCRIPTION



Fig. 1.

1. Place of attachment to the axis of the rear wheels/spreader bar,
2. Control module socket,
3. Rear drive,
4. Charger,
5. Control module.



## List of items inside the package



Fig. 2.  
Rear drive, main unit



Fig. 3.  
Two mounting brackets



Fig. 4.  
Spreader bar



Fig. 5.  
Charger



Fig. 6.  
Control module

## 2. USAGE

- After unpacking the packaging, check that it contains all the parts according to the list of components above.
- Make sure that all elements have no visible mechanical damage. If in doubt, contact the manufacturer.
- The module should not be used until all components are properly assembled on the wheelchair.

### 2.1 ASSEMBLY - CROSS FRAME WHEELCHAIR

1. Attach the spreader bar (Fig. 4.) to the wheelchair.

a) Unfold the wheelchair and attach the spreader bar to the two vertical tubes on the back of the wheelchair (Fig. 7.).

b) Select the appropriate width of the bar and tighten the bolt and eccentric clamps (Fig. 8.).

- tighten the screws of the eccentric clamps
- tighten the eccentric screws.

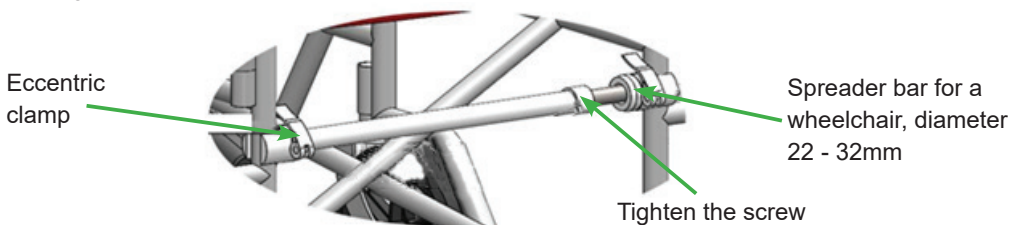

Fig. 7.

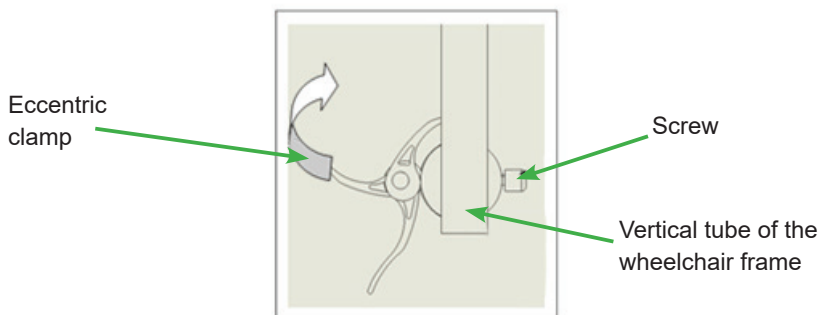
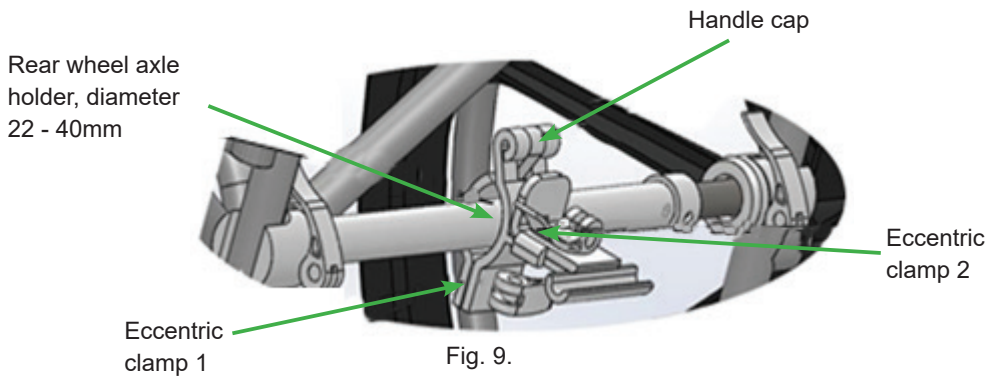

Fig. 8.

## 2.2 ASSEMBLY - FIXED FRAME WHEELCHAIR

1. Select the appropriate mounting bracket depending on the thickness of the rear wheels axle and the spreader bar.
2. Install the handle in the center of the axle and tighten it (Fig. 9.).
  - a) The cap of the handle should be above the axis/bar.
  - b) Tighten the eccentric clamp 1, which is in the horizontal position when tightened.
  - c) Lock it by slightly tilting it backwards.



## 2.3 FURTHER ASSEMBLY STAGES

3. Attach the rear module to the mounting bracket, then tighten the eccentric clamp 2 (Fig. 10.).
4. Check the stability and correct mounting of the rear drive.



Fig. 10.



### 5. Dismantling the rear module

- Release eccentric clamp 2 and pull the drive out of the mounting bracket (Fig. 11.).



Fig. 11.

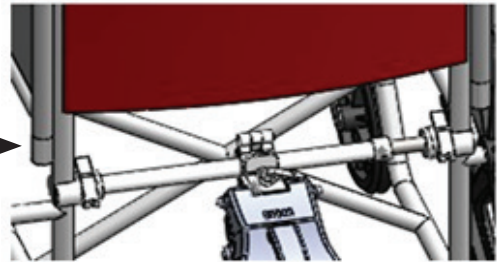

Fig. 12.

6. Then connect the control module (Figure 13.) to the rear module. To do this, screw the end of the cable with a pin to the control module socket on the right side of the module (Figure 14.).



Fig. 13.

Control module



Fig. 14.

Charging socket

Control module socket

7. The control module should be attached to the wheelchair frame with a strap so that it is within the user's hand (Fig. 15.).



Fig. 15



**Warning!**

The **safety switch** is not designed to shut down the drive during normal use. Use the **rotary switch** to safely reduce the speed and stop the drive.

**The manufacturer does not consider warranty claims caused by not using the control panel properly.**

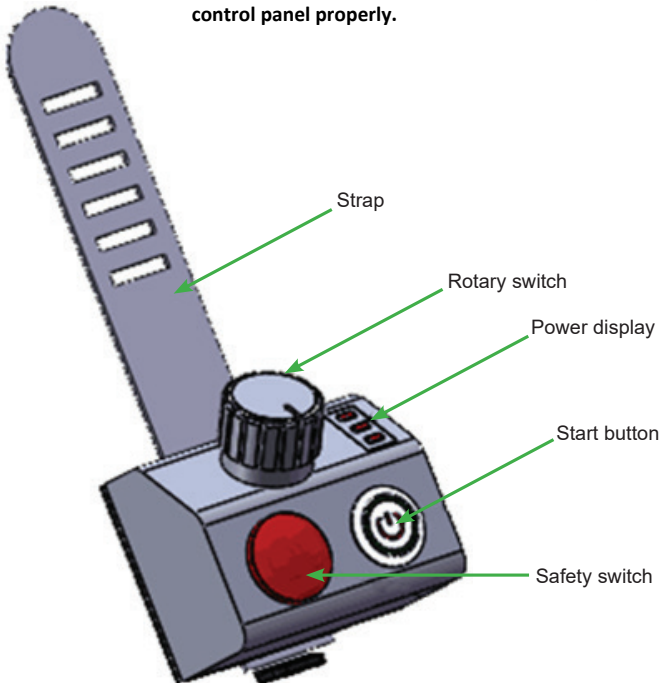

Fig. 16.



# 3. EVERYDAY USE AND MAINTENANCE

## Usage:

- The maximum load capacity is 100 kg.
  - Connect the rear drive to the wheelchair and turn on the power switch, then turn the rotary switch. When the switch is turned a third of the wheel, the module starts working.
- Speed: 0-7.5 km / h
- CAUTION! If the wheelchair speed is too high, please press the safety switch on the control module. Then hold the wheel of the wheelchair to stop the cart.
  - When the rear drive is operational, the drive wheels no longer need to be turned and the truck will travel in a straight line. It is recommended to constantly adapt the direction to road conditions and surfaces.
  - The rear drive can climb up to 8 degrees slopes.
  - When the light is green, the module is working properly. When the light is red, please charge it.
  - The battery has been charged before leaving the factory. When charging the battery, please insert the charger output into the charging socket first, then connect the AC input. Red light means charging; green light means charging is over.

## Comments:

- If you want to use the rear module, connect it to the wheelchair before turning on the module.
- To stop the module, please turn off the safety button, set the rotary switch to zero before leaving the cart.
- Do not lean back hard - danger of tipping over.
- If the module is not used for a long time, charge it every 3 months.

## Malfunctions:

- When the rear module fails to operate after turning on the rotary switch, this means that the rear module has failed. Please contact the supplier.

## Maintenance:

- The module should be cleaned with a damp cloth without the addition of detergents or other similar agents.
- It is necessary to remove contamination, eg threads, hair, etc., from moving parts of the wheelchair (wheels, footrests) on a regular basis.
- To maintain the operational parameters of the product, it is extremely important to keep all its elements clean and the manner of storage.
- Storage in rooms with very high humidity (baths, laundries, etc.), or in the open air, combined with the lack of hygiene, will result in a rapid loss of functional and aesthetic parameters.
- Do not expose the module to extreme weather conditions (rain, snow, very strong sun), as some elements may change color.

**Do not use:**

- solvents,
- toilet cleaners,
- agents with chlorine content,
- sharp brushes and hard objects,
- caustic cleaning agents,
- do not clean the device with pressure or steam generators!

**Repair:**

- In the event of repairs being necessary, please contact the manufacturer or the distributor.

**Customer service:**

- If you have any questions or need help, please contact the manufacturer or distributor.

## 4. DRIVE MODULE PARAMETERS AND STANDARDS

Weight	7 kg
Battery type	litowy
Battery capacity	6.6 Ah
Rated voltage of the control module	24V
Motor rated voltage	24V
Engine operating current	< 3A
Charger input voltage	110V - 220V
Charger output voltage	± 0.2A
Working temperature	-20°C - +60°C
Driving speed	0 - 7 km/h
Pod napięciem	21 ± 0.5V
CE markings	2014/35/EU Low Voltage Directive; 2014/30/EU electromagnetic compatibility
Standards	EN 60335-1:2012/A11:2014; EN 61000-6-1:2007; EN 61000-6-3:2007/A1:2011/AC:2012
Dimensions	470 x 150 x 200 mm (Max. crossbar spacing 410mm)
Energy range	20 km



## DISPOSAL OF WASTE ELECTRICAL AND ELECTRONIC EQUIPMENT

This symbol on the products or accompanying documents means that used electrical or electronic products should not be disposed of with the normal household waste. For proper disposal, refurbishment or recycling, please take these products to the collection points for this type of waste. Alternatively, in some EU countries or other European countries, you may return your product to your local retailer when purchasing a similar new product. By disposing of this product correctly, you will help to conserve valuable natural resources and support the prevention of potential negative effects on the environment and human health, which could result from incorrect disposal. For further information, please contact your local municipality or collection point waste collection points. Penalties may be imposed in accordance with local regulations if this product is disposed of in an inappropriate manner. For parties within the European Union, if you wish to discard electrical or electronic equipment, please obtain the necessary information from your retailer or supplier. Elimination in countries outside the European Union. This symbol is valid in the European Union. If you wish to decommission this appliance, please obtain the correct decommissioning information from your local authorities or from your retailer.



Medical device

## 5. CONTACT DETAILS



mdh Sp. z o. o.

ul. Maratońska 104, 94-007, Łódź, Poland

tel. +48 42 674 83 84, fax. +48 42 636 52 21

[www.mdh.pl](http://www.mdh.pl), [www.viteacare.com](http://www.viteacare.com)



**MDH Sp. z o.o.**  
**ul. Maratońska 104,**  
**94-007, Łódź, Polska**  
[www.mdh.pl](http://www.mdh.pl)  
[www.viteacare.com](http://www.viteacare.com)